

REVISIONS		
REV. NO.	DESCRIPTION	DATE

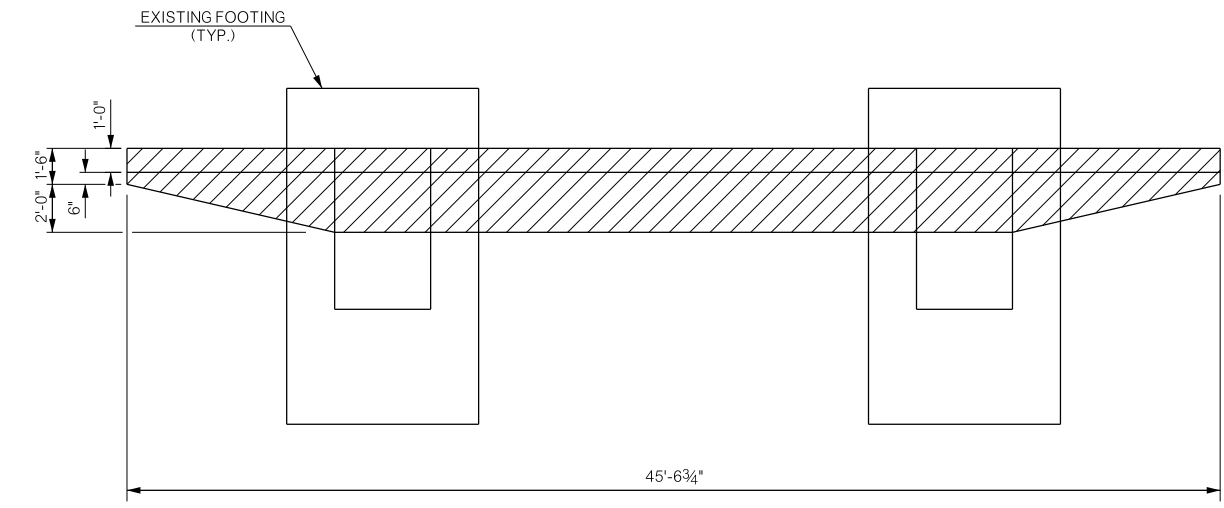

PLAN

NOTE: SAW CUT AND REMOVE TOP OF ABUTMENT CONCRETE AND REINFORCING TO A DEPTH OF 1'-0" BELOW THE EXISTING BRIDGE SEAT LEAVING ONLY EXISTING VERTICAL REINFORCING OF EACH COLUMN WHICH WILL BE CLEANED AND STRAIGHTENED.

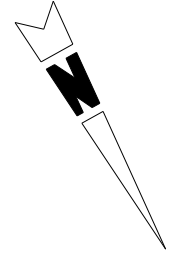
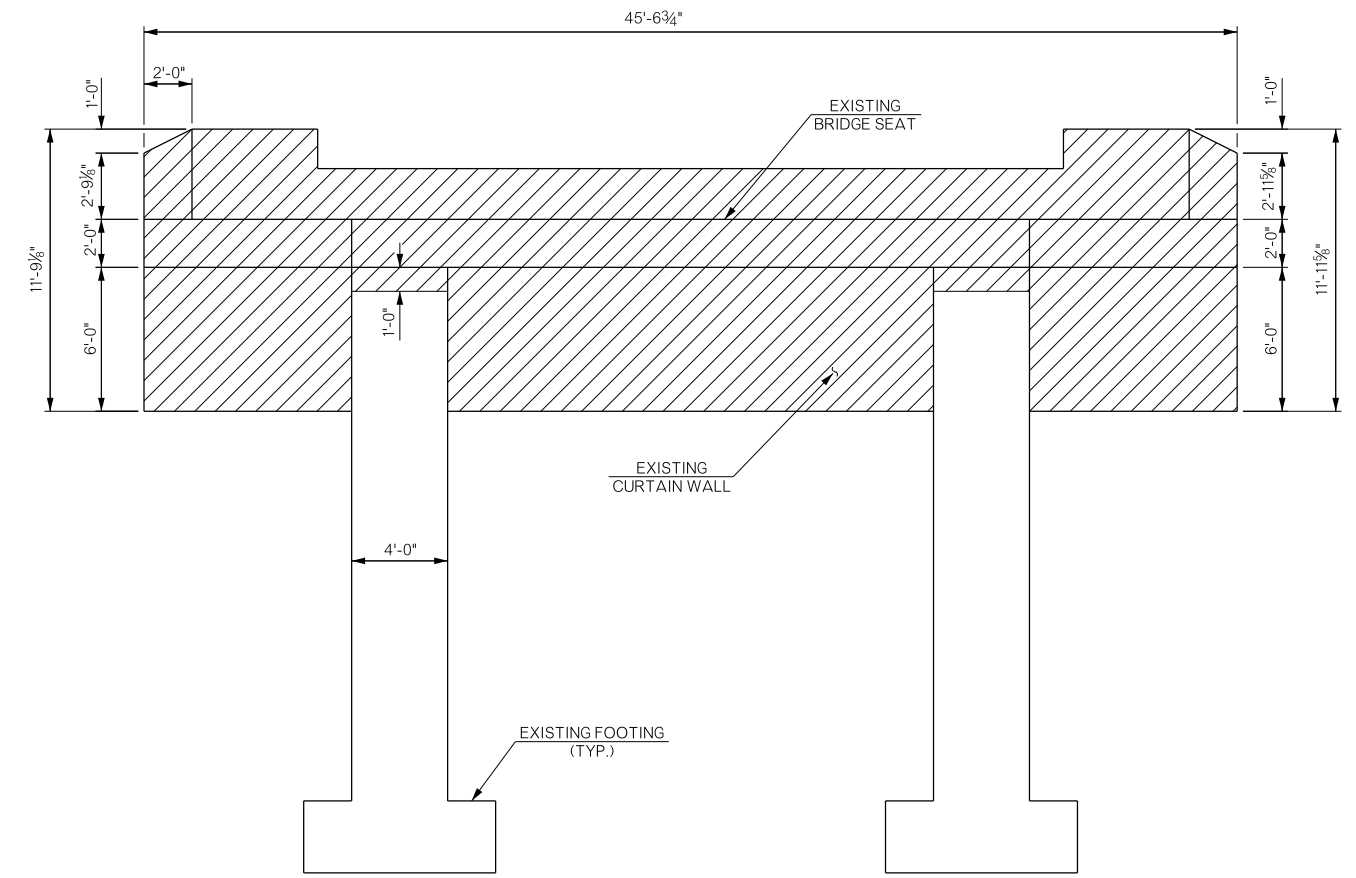

ELEVATION

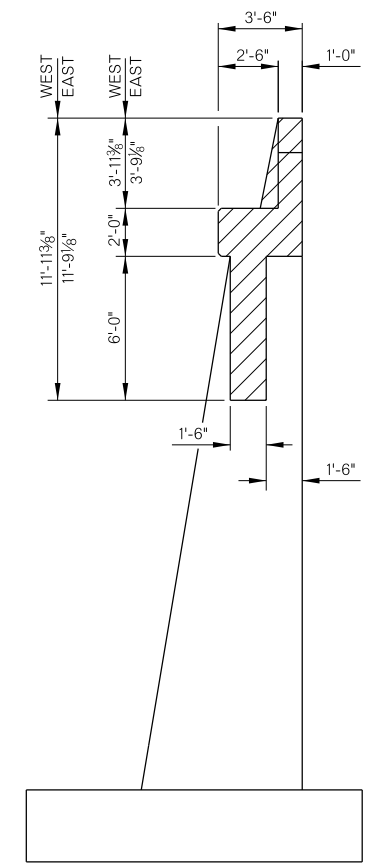

TYPICAL SECTION

PORTION OF EXISTING STRUCTURE TO BE REMOVED.

BRIDGE "A" SH-78 OVER CHUCKWA CREEK		BRYAN COUNTY		Design	CJO	6/15
ABUTMENT NO. 1 DETAILS (SHEET 1 OF 4)				Detail	DPG	8/15
				Check	TEE	9/15
STATE OF OKLAHOMA				DEPARTMENT OF TRANSPORTATION		
JOB/PIECE NO. 27912(04)				SHEET NO. B005		